

DESIGNING FOR VERTICAL PIPE DEFLECTION UNDER HIGH LOADS

Mark E. Smith, P.E., G.E.
Vector Perú S.A.C., Lima PERÚ

Abigail Beck, E.I.
Vector Engineering, Inc., Grass Valley, CA USA

Richard Thiel, P.E.
Vector Engineering, Inc., Grass Valley, CA USA

Phil Metzler, E.I.
Consultant, Santiago CHILE

Key words: heap leach, landfill, pipes, culverts, deflection, Burns-Richard, Soil Modulus, ADS, N-12, high load

ABSTRACT

The deflection of corrugated dual-walled polyethylene pipe was investigated in the laboratory. Laboratory deflections were compared to those predicted by the Burns-Richard model under vertical loads of up to 112 meters of fill height (1,900 kPa). Test temperatures ranged from ambient to 60°C. Load and temperature ranges were selected to simulate conditions on copper and gold leach pads, though these conditions can also be applicable to large landfills. The results of the comparisons indicate good correlation between laboratory measurements and the Burns-Richard solutions for vertical deflections to the maximum depths considered, but that soil modulus values from the literature need to be adjusted for the higher load conditions. Horizontal deflections did not correlate, suggesting that either the Burns-Richard model is incorrect for this condition or that soil modulus under these loading conditions is anisotropic. Recommendations for applications of these findings in design practice are presented.

INTRODUCTION

Heap leaching is an increasingly common method of extracting gold, copper, and, to a lesser extent, silver and nitrate from ores. In this process, ore is stacked on a lined area then irrigated with either a weak alkaline/cyanide (gold and silver) or weak sulfuric acid (copper) solution, or plain water for nitrate salts. The ore might be any size range including run-of-mine or crushed to fine gravel. The irrigation solution dissolves the minerals through chemical or biochemical means. The solution is collected at the base, the mineral is recovered from the solution, and the solution is (usually) recirculated to the heap. Reliable drainage systems are required at the base of the heap to improve mineral recovery, reduce seepage through the liner system, improve slope stability and reduce liquefaction potential (see for example Castillo et al 2005 and Smith 2002). These drainage systems almost universally consist of a layer of granular material and perforated pipes. Lateral pipes typically range from 65 mm to 152 mm in diameter, feeding

main “header” pipes of much larger diameter. It is the smaller lateral pipes that were the focus of this study, but the results should be applicable to pipes of any diameter. In most cases the laterals and headers are dual wall corrugated polyethylene (CPE) pipes. The most common pipe marketed in the mining industry in North and South America is Advanced Drainage Systems (ADS) N-12. This pipe is manufactured in diameters of up to 60 inches (1,524 mm). The pipe chosen for this study was N-12 in 6 inch (152 mm) nominal diameter (151 mm and 175 mm actual ID and OD, respectively), weighing 1,788 grams per meter length and with inner and outer wall thicknesses of 1 mm.

Heap leach applications have long been pushing the envelope of known performance for geosynthetic products (see for example Thiel and Smith 2003). Modern heap leaching started in the mid-1970’s in the Western U.S. At that time maximum heap heights were typically limited to 10 to 30 meters and the importance of a well performing drainage system was not fully recognized. Over the ensuing three decades the operating conditions have changed dramatically. Now heaps commonly exceed 100 m in height over the drainage pipes, and 180 m and more are being explored (Breitenbach et al 2005, and Thiel and Smith 2003). At the same time very little data has been available on the performance of the drainage pipes under such high loads and some heap drain pipe failures are known. The industry started to feel the effects of this data gap when the first heaps were designed to exceed 100 m in the second half of the 1990s, and started to fund limited laboratory programs to evaluate high load performance. The authors’ laboratory has been one of the principal facilities performing this testing and thus has accumulated about a decade worth of testing data. More recently, with heaps of 145 m and higher being designed (and in at least two cases under construction), the laboratory programs have become more extensive. This paper presents the results of a single set of testing, but those results are consistent with the other tests that came before and, as such, this data should be considered to be more representative than the single test program from which it was produced. The larger data base is not presented here due in part to time limits in preparing the data for presentation, in part due to confidentiality requests and because some of the data has been presented elsewhere (see for example Smith 2003, and Leduc and Smith 2004).

THE BURNS-RICHARD SOLUTION AND LABORATORY EXPERIENCE

The most commonly used methods for predicting the deflection of buried pipes are the Modified Iowa Formula (Spangler, 1941) and the Burns-Richard (1964) solution. The Modified Iowa Formula is based on empirical relationships from known field performance and is limited primarily to maximum burial depths of 7 meters. The main manufacturers of CPE pipe routinely provide Burns-Richard (BR) solution spreadsheets and nomographs to specifiers and purchasers, and the literature commonly references BR solutions (see for example <http://www.ads-pipe.com/us/en/technical/pipetech.shtml>, Lupo and Morrison 2005, Goddard et al 2003, and Sargand et al 2000). Thus, while many more sophisticated methods now exist, it is the authors’ experience that many practitioners rely on the BR solution.

When laboratory testing started to consider very large burial depths for heap leach operations it was found that standard BR solutions did not correlate well with the laboratory results. The basis for this lack of correlation was not well understood and at least some practitioners attributed it to an inherent limit of the solution itself. In two recently published

studies the BR solution compared unfavorably to more rigorous analyses and a wide range of soil moduli were found from direct testing (Dhar et al 2004 and Sargand et al 2005). The testing and analysis presented in this paper were in part a response to that suspected limit with the goal of adapting the BR solution to greater depths. Through various iterations and processing of this and other test data it was ultimately determined that with proper soil modulus the BR solution compared well with laboratory results for vertical deflections to the maximum loads considered. With this finding, the focus of the work shifted to the question of soil modulus.

In applying the BR solution it is common to use published values for soil modulus (E'). Values have been given by Duncan and Hartley (1982) in tabular form for soil depths of up to 6 m of soil burial. Goddard et al (2003) provides an equation for extrapolating the modulus of soil reaction at a low overburden pressure to any depth:

$$E' = E'_5 (1 + 0.15 (H-6)^{0.5}) \quad (1a)$$

Where E' is the soil modulus at the depth of concern (units consistent with E'_5), E'_5 (any units) is the soil modulus at a depth of five feet and H is the overburden height or depth of burial (feet). This equation can be transformed to metric as follows:

$$E' = E'_{1.5} (1 + 0.27 (H-1.8)^{0.5}) \quad (1b)$$

Where $E'_{1.5}$ is the soil modulus at a depth of 1.5 m and H is the overburden height or depth of burial (m).

There is no limit in terms of depth stated for the BR equation, and it is inferred by the above equations that soil modulus can be extrapolated to any depth. However, there is a limit to the available data on soil modulus and on verification of the BR solution at great depths. The work presented in this paper extends that limit.

TEST METHODOLOGY

The test apparatus used for this study consisted of a stiff steel box with plan dimensions of 760 x 600 mm and a height of 620 mm. The box had access portals on two sides near the base to allow visual observation and measurement of pipe deformation during the test. The box floated around the test materials, which rested on a bottom plate, in order to minimize friction along the side walls and thus reduce their affect.

The materials placed in the box consisted of a subgrade soil, a geomembrane, drainage pipe, an "overliner" gravel, and overburden gravel. This is the typical drainage configuration used in heap leaching. Compacted sand was used for the subgrade so that the material could be placed with a minimal amount of variation between tests. A 2.0 mm thick high density polyethylene (HDPE) smooth geomembrane liner was then placed over the subgrade, and the pipe rested directly on the geomembrane. Overliner gravel was placed on both sides and over the pipe for approximately 80 mm vertically. Aggregate base gravel was then added to fill the remainder of the box. The gravels were lightly compacted, representing typical practice for heap leach pad construction. The vertical overburden loads were then applied through a pressure

bladder reacting against a stiff loading frame. The pressure bladder applies the vertical pressure equally over the top surface area of the box as the pipe and gravel deform. A cross section of the assembled test apparatus is shown in Figure 1.

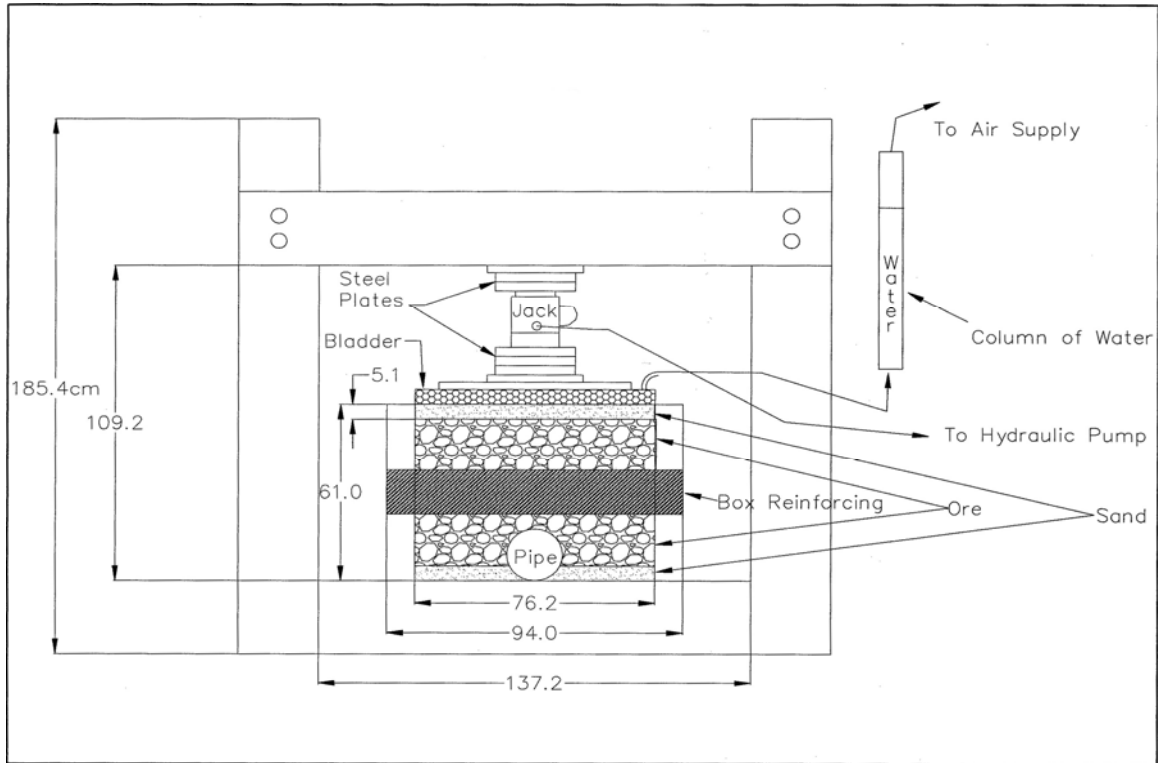

Figure 1 - Test Apparatus

The overliner gravel used in the test was a nominal minus 38 mm (1-1/2 inch) or 100% minus 57 mm (2-1/4 inch) crushed stone similar in composition to aggregate base rock used in highway construction. The gravel was placed in uniform lifts and lightly tamped to achieve approximately 75% relative density (ASTM D4253 and 4254). Great care was taken to ensure uniform compaction within and between tests. The dry density of the overliner before and after the tests averaged 1,922 and 2,146 kg/m³, respectively, indicating significant densification during the test.

Before loading, a strain measuring system was attached to the inside of the pipe. This system is a simple mechanical wire gage. Starting with eye-bolt pairs at the x and y ordinates at the pipe center, a small Teflon coated 20-gage wire is hooked into the first x-eye then down and through the second x-eye, then run outside to an externally-fixed pivot point and to a light spring. A similar arrangement was used for the y-eye bolts. A marker is used at or near the spring to note against a millimeter scale position changes in the length of the wire.

The loads were applied in increments of approximately 200 kPa, and maintained for approximately 10 minutes before the next increment. The maximum load (approximately 1,900

kPa) was applied for a period of 48 hours. The vertical and horizontal deformations were recorded at the end of each time interval. The condition of the pipe was also visually observed throughout testing to note any buckling or unusual behavior. A typical experimental set-up is shown in Photo 1. Both vertical and horizontal deflections were measured, as shown in Photos 2 and 3 (*photos courtesy of Vector Engineering, Inc.*)

RESULTS AND ANALYSIS

Copper sulfide ore leaching can produce elevated temperatures in the base of the heap due to biological reactions and this is believed to reach 45 or 50°C. The four pipe load tests were run at four different temperatures: 22°, 40°, 50°, and 60°C (labeled as A, B, C and D, respectively, in the figures). The gravel and pipe were heated for several days prior to applying the first load; the temperature was maintained with a heat gun and monitored throughout each test series. Although an increase in temperature from ambient (e.g., 23°C) to 50°C can reduce the modulus of elasticity of polyethylene pipe by 50% (Smith 2003), the BR equation is relatively insensitive to this parameter; the laboratory results also show this. Figure 2 summarizes the pipe performance for the four temperatures considered. Since temperature had little effect, the pipe modulus at ambient was used in the balance of the study and the four tests were considered together.

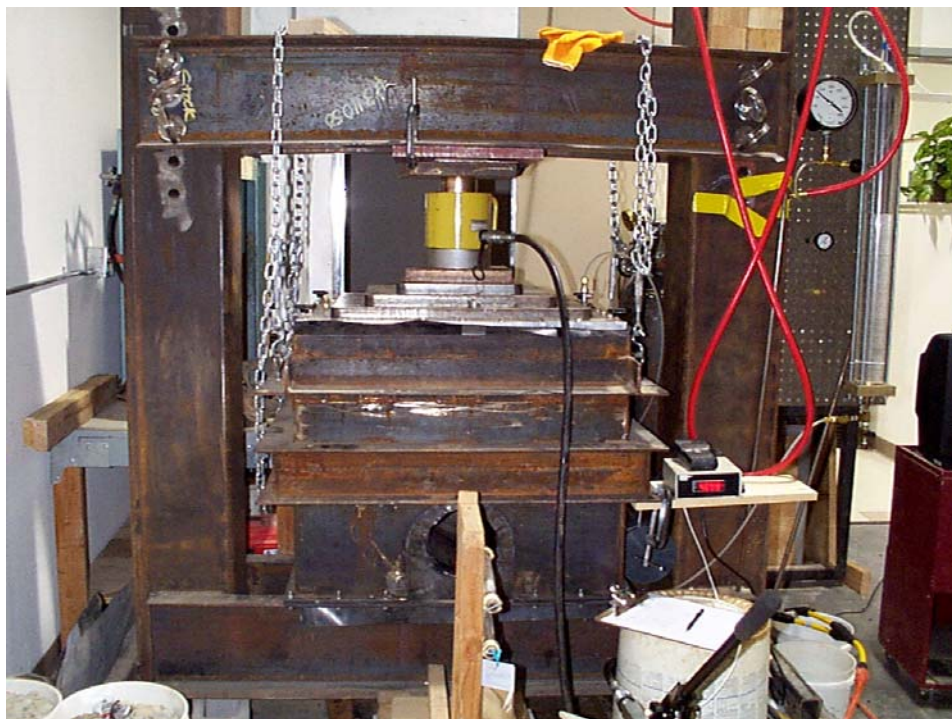

Photo 1 - Test Apparatus



Photo 2 - Deflection Measurement System Before Test



Photo 3 - Pipe Deflection at Maximum Load for Series C

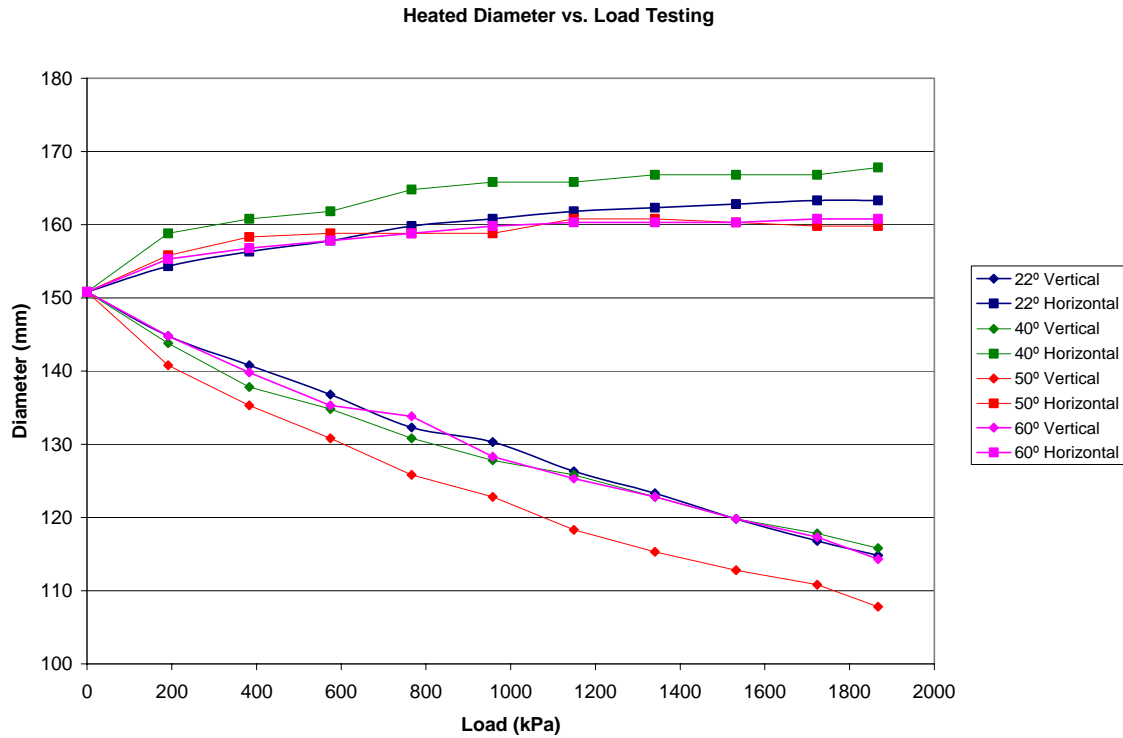

Figure 2 - Pipe Loadings and Varying Temperatures

The soil modulus for each load increment for each test was back-calculated using the BR model. These results are presented in Figure 3, which shows good repeatability between the four tests. The equation for vertical soil modulus was found to be:

$$E'_{sv} = -\rho^2/1,250 + 4.5\rho + 3,530 \quad (2a)$$

Where E'_{sv} is the vertical soil modulus (kPa) and ρ is the overburden pressure (kPa).

If test series “C” is considered an outlier, due possibly to soil preparation, its influence on the equation can be reduced. The inclusion of the “C” series causes Eq. 2a to flatten at high loads and eventually for the slope to reverse, which is certainly not true soil behavior. Thus, Eq. 2a becomes unreliable at overburden depths greater than about 120 m. More realistic behavior at the higher loads can be achieved by modifying the first term slightly (and rounding the y-intercept for convenience), as shown in Eq. 2b:

$$E'_{sv} = -\rho^2/1,650 + 4.5\rho + 3,500 \quad (2b)$$

Where the final term, 3,500, approximates the modulus at a nominal shallow depth, such as $E'_{1.5}$. Eq. 2b is within 5% of Eq. 2a for overburden depths under 100 m. At 120 m the difference is 8% and at 150 m it is 12%. Based on the shape of this equation and expected soil behavior, Eq. 2b may be reliable to about 200 m. This has not, however, been experimentally verified. This relationship can be transformed and expressed in terms of height of overburden (depth of burial) and soil modulus at 1.5 m ($E'_{sv1.5}$, kPa) as follows:

$$E'_{sv} = -0.17H^2 + 75H + E'_{sv1.5} \quad (3)$$

Where H is overburden height or depth (m) and E'_{sv} is vertical soil modulus (kPa). Eq. 3 is expressed for an overburden soil total density of $1,700 \text{ kg/m}^3$; the transformation can be made for any overburden soil density.

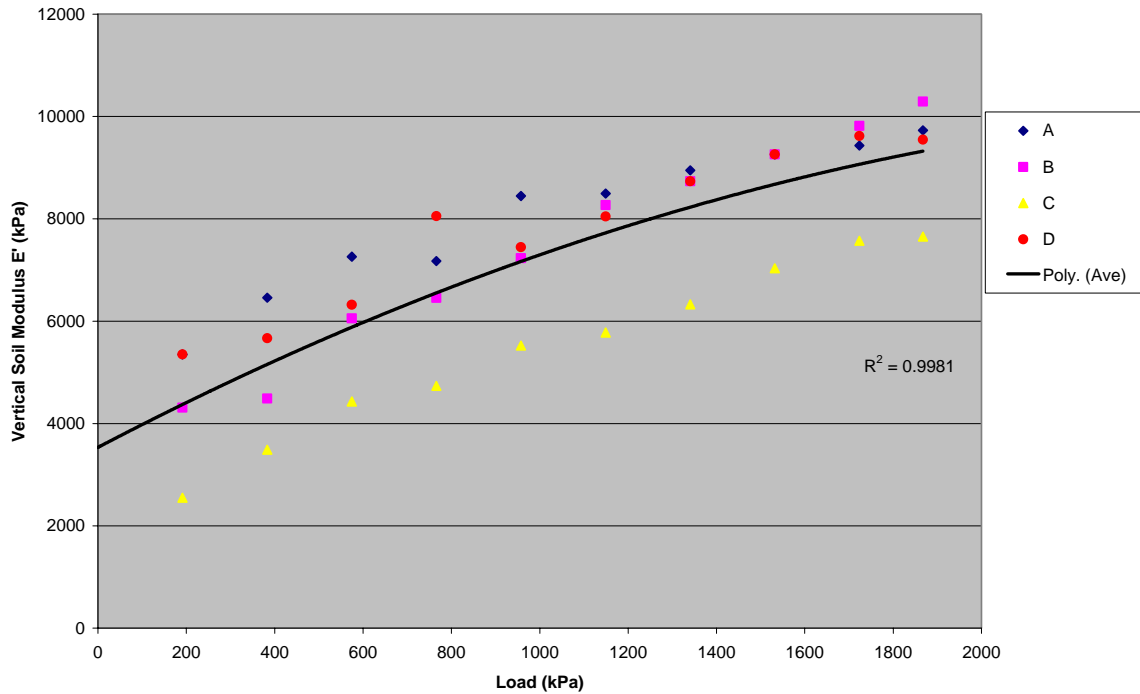

Figure 3 - Calculated Vertical Soil Modulus

Table 1 presents a comparison of Eq. 2b with selected literature values for granular soil and the values found in this study. This shows considerable variance between literature sources and with the results of this work.

Table 1- Comparison of Literature Values of Modulus to This Study

Height (m)	Vertical Load (kPa)	Soil Modulus, E' (kPa)			
		Eq. 2b	Goddard et al (2003) Eq.1b	Dhar et al (2004)	Sargand et al (2005)
6	100	3,950	5,450	5,100	13,950
10	170	4,300	6,200	6,400	18,300
24	400	5,250	7,950	9,600	nr
50	830	6,850	10,050	nr	nr
100	1,670	9,350	12,850	nr	nr
120	2,000	10,100	13,750	nr	nr
150	2,500	11,000	15000	nr	nr

Notes to table:

1. nr = not reported in referenced citation.
2. $E'_{1.5} = 3,500$ kPa used for Eq. 1b and 2b.
3. Eq. 2b was developed for crushed stone at approximately 75% initial relative density.
4. Dhar values are secant modulus, which more closely matches Eq. 2b than the alternative, average modulus. E' at 10 m has been interpolated.
5. Sargand values were averaged for sand and crushed limestone at 86%, the lowest compaction reported.

Horizontal soil modulus proved more complicated to analyze and, in fact, the back-calculation process did not produce reliable or reproducible results, as shown in Figure 4. The reason is unclear and this is the subject of on-going study. What was clear is that the horizontal and vertical moduli are different for this loading condition (e.g., for 1,000 kPa overburden pressure the vertical and horizontal moduli were about 7,000 and 5,000 kPa, respectively). That difference may be a result of the different stress paths experienced by the soil on top of and along side the pipe. The soil over the pipe can be idealized as in an at-rest or partially-mobilized passive pressure state, while the soil along the side of the pipe is, at least for the higher pipe deflections, in a fully mobilized passive pressure state. That soils are stiffer under passive pressure is well established, though these results suggest a lower value for horizontal modulus in comparison to vertical. There is also more variation or scatter in the horizontal data, which may be due to the inherent difficulty in uniformly placing and compacting the soil beneath the curve of the pipe; loose soil here might have a larger effect on horizontal deflections than on vertical. Dhar et al (2004) reports, and experience would suggest, that values of the elastic modulus of soil are reduced in the haunch zone under the pipe due to less compaction effort than the surrounding soil.

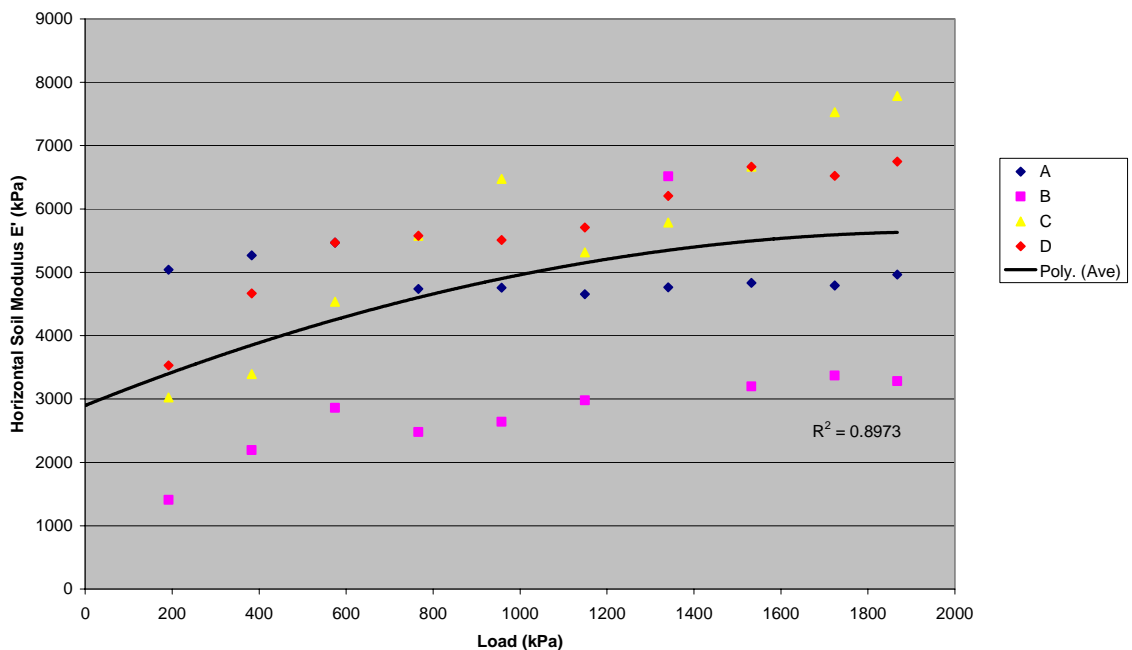

Figure 4 - Calculated Horizontal Soil Modulus

SUMMARY

The authors have shown that the Burns-Richard solution can be duplicated in the laboratory for large overburden pressures using calibrated values for vertical soil modulus (E'_{sv}). They have also shown that published values for soil modulus vary significantly from source to source and from those found by this study. Further, the available published figures do not extend to sufficiently great overburden pressures to be useful in modern heap leach design (this limitation may also apply to other applications such as large landfills). The work presented herein provides vertical soil modulus, E'_{sv} , for overburden pressures to 1,900 kPa for a nominal minus 38 mm (1-1/2 inch) crushed stone at approximately 75% relative density (Eq. 2b). With additional testing Eq. 2b could be adapted to different soil types or relative densities on a project-by-project basis.

Ultimately, the purpose of this work was to develop design tools and guidelines for deep burial of drainage pipes, principally for heap leaching but also applicable to landfills. Design implications from this study include:

- The CPE pipes performed well under the maximum loads tested. Vertical deformation and flow area reduction of 25% and 19%, respectively, were observed at 112 m (1,900 kPa) of overburden, but the pipes retained structural integrity and no buckling was observed even in the highest deflection data set, series C (Photo 3). This suggests that dual-wall CPE pipe is suitable for the load ranges considered. However, other testing found that buckling of this pipe occurs with vertical deformations between 25% and 35% of original inside diameter. Buckling results in significant loss in flow area (as much as 50%) and loss of structural integrity, compromising the pipe's ability to withstand subsequent load increases and the integrity of the joints. Given this, the ultimate limit for this pipe may be in the range of 120 to 140 m without improvement in installation procedures such as better quality, higher relative density gravel or stiffer pipe.
- The BR solution appears to be valid heap depths of up to 112 meters (1,900 kPa), and probably beyond since this testing shows no divergence from the BR solution at the maximum depth tested. Eq. 2b, however, may require further calibration for higher loads.
- Soil modulus for vertical loading varies from literature values. Further, the range of data available in the literature and the use of broad classifiers such as "granular", "mixed", "good" and "fair" is too vague to allow adequate quantification for high loads. Therefore, project-specific testing is required unless the soils are similar to those presented herein, in which case Eq. 2b can be used (with caution).
- A transformation of Eq. 2b is presented as Eq. 3 for estimating the variation of vertical modulus with depth from a known modulus, for overburden soil density of 1,700 kg/m³. the equation can be adapted to other overburden soil densities.
- Soil modulus may be different for vertical and horizontal conditions. The BR solution may require revision or the use of anisotropic values for E' for accurate prediction of horizontal deflection under higher overburden pressures. More work is needed in this area.
- Temperature, within the range considered (ambient to 60°C), does not significantly affect pipe deflection. The maximum temperature expected in heap leaching, which occurs at

the base of copper sulfide heaps, is about 45°C. Similar temperatures can be expected within bioreactor landfills.

- Since the BR solution is (apparently) reliable under these loads, it is reasonable to extend this to other pipe diameters, other soil types and higher overburden pressures. Since laboratory testing is relatively easy for smaller diameter pipes, one method for applying this study to design cases is to test various soil types with a single pipe size, back calculate the vertical soil modulus, E'_{sv} , and then use those values for predicting deflections of various other combinations of soil types, pipe diameters and overburden pressures.
- An issue unrelated to this paper but which also arose in the same testing program was the increase in normal load on the geomembrane adjacent to the pipe. It is logical that the pressure here would increase, since the arching effect of the flexible pipe causes the vertical load on the pipe to decrease and force equilibrium requires a compensating increase elsewhere. Load cells in the test apparatus and subsequent finite element analyses found that this over-pressurization reaches a peak value of about 125% of the average vertical stress at a distance of one pipe diameter away from the pipe. The zone of over-pressurization extends to about four pipe diameters to each side of the pipe (Leduc and Smith 2004). The design implication is that a more robust liner system, in terms of puncture protection, maybe be required than would otherwise be indicated.

ACKNOWLEDGEMENTS

This study was financed in part by Vector Engineering, Inc. and various mining companies. Some work referenced herein and important to the findings, but not directly reported, was financed by CPE pipe manufacturers including Advanced Drainage Systems and Tehmco Chile. The laboratory testing was performed at Vector's headquarters laboratory in Grass Valley, California, under the supervision of Ken Criley.

REFERENCES

- ADS (2005) "N-12/Dual wall Burns and Richard solution" <http://www.ads-pipe.com/us/en/technical/pipetech.shtml>.
- Burns, J. Q. and Richard, R. M. (1964) "Attenuation of stresses for buried cylinders" Proc. Symposium on Soil-Structure Interaction, Engineering Research Laboratory, University of Arizona, Tucson, AZ, 378-392.
- Breitenbach, A. J. (2005) "Improvement in Slope stability performance of lined heap leach pads from design to operation and closure" (These proceedings).
- Castillo, J., Hallman, D., Byrne, P. and Parra, D. (2005) "Dynamic analysis of heap leach pad under high phreatic levels" proc. XXVII Convención Minera, Instituto de Ingenieros de Minas de Perú, Arequipa, Perú, September 12-16.

Dhar, A. S., Moore, I. D., and McGrath, T. J. (2004) "Two dimensional analyses of thermoplastic culvert deformations and strains" Journal of Geotechnical and Geoenvironmental Engineering, February p. 199.

Duncan, J. M. and Hartley, J. D. (1982), "Evaluation of the modulus of soil reaction E' and its variation with depth" University of California, Berkeley.

Goddard, J. B., Kampbell, N. E., and Kozman, D. P. (2003), "Technical Note 2.130: Structural performance of corrugated PE pipe using the Burns and Richard solution" <http://www.ads-pipe.com/us/en/technical/pipetech.shtml>.

Leduc, M. and Smith, M. E. (2004), "Solution collection pipes & overstressing of geomembrane liners" The Mining Record, September.

Lupo, J. F. and Morrison, K. F. (2005), "Innovative geosynthetic liner design approaches and construction in the mining industry", Golder Associates internal publication available on line at <http://www.golder.com/default.asp?PID=77&VID=164&LID=26>.

Sargand, S.M., Masada, T., Tarawneh, B. and Gruver, D. (2005), "Field performance and analysis of large-diameter high-density polyethylene pipe under deep soil fill" Geotechnical and Geoenvironmental Engineering, January p. 39.

Sargand, Shad M. and Masada, T. (2000), "Performance of large-diameter honeycomb-design HDPE pipe under a highway embankment" Canadian Geotechnical Journal 37(5): 1099-1108.

Smith, M. E. (2003), "Drainage pipe deflection for high heaps" The Mining Record, December.

Smith, M. E. (2002), "Potential Problems in Copper Dump Leaching," in Mining magazine, July.

Spangler, M. G. (1941), "The structural design of flexible pipe culverts" The Iowa State College Bulletin, No. 30, Vol. XL, Iowa Engineering Experiment Station, Iowa State College, Iowa.

Thiel, R. and Smith, M. E. (2003), "State of the practice review of heap leach pad design issues" Proc. of the December GRI conference, Las Vegas, Nevada, December.