

Guidance on the Design and Construction of Leak-Resistant Geomembrane Boots and Attachments to Structures

R. Thiel, Vector Engineering, Grass Valley, CA, USA

G. DeJarnett, Envirocon, Houston, TX, USA

ABSTRACT

Experience in reviewing, designing, performing field inspections, and installing of geomembrane boots and connections to structures has revealed a widely diverse practice of standards and approaches. The execution of these details is very much an art in workmanship, and depends a great deal on the experience and understanding of the installer. There is very little guidance in the literature regarding the fine points of specifying and installing these critical details. The typical manufacturers' details and guidelines are not much more than concepts that have been repeated for two decades. Thus, there is a big difference between what we assume and expect versus what is constructed in terms of leak resistance of geomembrane penetrations and attachments to structures. The goal of this paper is to touch upon some of the detailed and critical aspects that should be addressed when specifying and constructing geomembrane seals around penetrating pipes (referred to as "boots") and attachments to structures.

1. INTRODUCTION

While much attention has been paid in the last 30 years to many other containment issues related to geomembranes (such as chemical compatibility, aging and durability, manufacturing, seaming, subgrade preparation, covering), there is surprisingly little technical discussion related to the design and construction of leak-resistant penetrations and attachments to structures. This subject has largely been relegated to a few simple details, mostly generated by the manufacturers and included in their standard literature.

The content of this paper is derived from the authors' field observations, experience, and deductive reasoning. In addition, a number of other experienced field installers and construction quality assurance (CQA) personnel were interviewed for their opinions related to the subject of this paper. The interviews revealed significant differences in opinions and approaches, sometimes contradictory to one another. There is a large opportunity for more academic studies in this area so that these critical connections can be more definitively engineered, specified, constructed, tested, and maintained.

The subject of this paper relates to those connections that the designer wishes to be leak-resistant, and not simply just a mechanical termination. Many mechanical terminations might have strength as a key design consideration. Most leak-resistance connections should be designed to be as stress-free as possible. For those terminations that need to provide both functions, the design must include provisions for both stress and containment.

When specifying or designing leak-resistant boots or attachments, the lead author finds it more appropriate to think in terms of "leakage impedance" rather than "leak-proof". The reason for this is clear: there is a significant probability that some amount of leakage may develop at these connections. The differences in materials, difficult-to-access geometries, the propensity for creating stress concentrations, the inability to non-destructively test, and the aging and cracking of sealants and gaskets all lead to a higher probability for leakage at these locations than there is in the free-field geomembrane. Thus, one key piece of advice for designers and owners is to be prepared to properly manage the consequences of potential leakage from these locations. Owner-management techniques are beyond the scope of this paper, but could conceptually include such design and operational elements as double liners with leak detection, and enhanced monitoring and response times.

2. BACKGROUND

There is relatively little detailed literature on the subject of designing and constructing leak-resistant geomembrane (GM) seals around pipe penetrations (called "boots") and sealing of geomembrane attachments to structures. What little exists is usually very general and lacking in specificity, with the exception of Wells (1993) and ASTM D6497. A brief review of available literature follows.

Koerner (1994). In the classic *Designing with Geosynthetics* by Koerner (1994) there are less than two pages of text on "connections" and "appurtenances", and some generic figures covering the entire subject. Probably the most well-directed statement in this reference is on page 594 that states "Care and true craftsmanlike work are required for trouble-free and leak-free performance." Other than generally portraying the concepts of penetrations and attachments, there is little substantive guidance on designing and constructing leak-resistant attachments, nor does it point to any references that would make this point.

Daniel and Koerner (2005). In the United States a very useful reference is by Daniel and Koerner (2005) entitled "Guidance for CQA and CQC of Liner and Cover Systems". This work, currently published under the auspices of ASCE, was originally sponsored by the EPA in 1993 with the title "Technical Guidance Document for QA and QC for Waste Containment Facilities". While this document has been of great service to the industry to provide overall support of uniform increased quality in lined installations, it is weak on the subject of boot and attachment details. The brief, less-than-one-page, section on Liner System Penetrations gives very little advice to the goal of constructing a leak-resistant penetration. For example, while the guidance suggests that a pipe-boot skirt should be nondestructively tested with a vacuum box or an air lance, it neglects to mention that the most common type of nondestructive testing in this application is spark testing of an embedded copper wire. The guidance is also misleading in its first recommendation, which suggests that "geomembrane pipe boots are usually factory fabricated" and are only field fabricated in "unique" situations. Quite the opposite is true! The lead and secondary authors have each been a design/CQA practitioner and an installer, respectively, for over 20 years and it is very rare that factory-fabricated boots are utilized. Even when pre-fabricated boots are explicitly specified in the contract documents, it is a very small probability that the installer will provide them, and you could safely bet that most of the boots will be field-fabricated. Furthermore, this guidance document does not provide any discussion of other types of leak-resistant attachments to structures.

Bonaparte et al. (2002) prepared a document for the USEPA's Risk Management Research Laboratory with the goal of evaluating the performance of waste containment design, construction, and operations in the United States, and providing recommendations for improvement. Their study identified a few case histories where pipe penetrations were a problem. Based on these case histories and other general observations, they made the following general statements in various sections of the report:

- "These case histories demonstrate that it is difficult to construct pipe penetrations to be hole free even when extra measures are taken to enhance the integrity of the connections."
- "...all of the design, construction, and operation problems identified in this investigation can be prevented using available design approaches, construction materials and procedures, and operation practices. It is the responsibility of all professionals involved in the design, construction, operation, and closure of waste containment systems to improve the practice of waste containment system engineering"; and also "...the frequency of these problems can be reduced with good design, construction, CQA, and maintenance."
- More specific training of design engineers, CQA personnel, contractors, and operators would reduce the occurrence of problems.
- Development of better construction materials, techniques, and QA/QC procedures to prevent the kinds of construction problems identified in their report.
- It is difficult to construct pipe penetrations of liners to be defect free. A method that was successful for one landfill was to fill the space between the pipe and pipe boot with bentonite slurry. Until new methods for constructing better connections between GMs and ancillary structures have been developed and tested, designs without pipe penetrations (i.e., designs with internal sumps) should be preferred.
- If boots are necessary, use prefabricated boots to minimize extrusion welds.
- Connections between GMs and ancillary structures should be carefully constructed and inspected to decrease the potential for construction-related GM holes.
- Pipe penetrations of liners should be leak tested by ponding tests, leak location surveys, gas tracer tests, or pressure tests of double pipe boots as part of liner system CQA.

Wells (1993). The paper by Wells (1993) is an excellent attempt to define the specifics of the design and construction challenges related to attaching a geomembrane to a concrete structure using a gasketed batten strip. Key elements of a successful leak-resistant connection pointed out in the paper were: (a) smoothness of geomembrane welded seams and the absence of wrinkles under the batten footprint; (b) uniform batten clamping pressure with a controlled strain in the gasket provided by a rigid batten strip, bolts, and nuts; and (c) smooth finish and strength of the concrete substrate. The greatest proportion of the paper is devoted to the education of the reader regarding the allowable compression of rubber gaskets. The paper makes the point that a recommended hardness for gaskets is generally 40 durometer, and that compression of gaskets more than about 10-15% (depending on thickness and shape factor) of their thickness will exceed their elastic limit, cause them to "cold flow" (deform plastically), and lose their resiliency. According to the method presented in the paper, a

typical ¼" thick by 2" wide gasket, which is the most common size used in the industry, should only be compressed about 7% of its thickness. Assuming that the anchor bolts are the common 3/8" dia. by 16 threads per inch, this would only allow the anchor-nuts to be tightened about *one-quarter of a turn* past finger-tight. As recognized by Wells (1993), thin gaskets are often overtightened relative to this design approach. The practical consequences of the paper's conclusions are that designers should specify thicker gaskets (allowing more compression and more turns of the nut) that are relatively lightly compressed by measuring turns of the nut rather than by measuring torque. Although Wells (1993) recognizes that the concrete substrate must be very smooth, and that the ridge formed by the lap joint of the geomembrane seam needs to be very small, the current authors would find that such light compression of 40-durometer material would generally be inadequate to close off the voids commonly caused by uneven substrates and 60-mil geomembrane lap joints.

ASTM D6497. The ASTM Guide D6497 provides a very competent industry standard, and was likely developed with input from Larry Wells. The Guide provides guidance on many critical aspects of geomembrane boots and attachments including the following: (a) the need for a smooth and even substrate; (b) edges and corners of structures should be rounded and cushioned with no voids to protect the approaching geomembrane; (c) precautions against differential settlement of the structure and adjacent ground should be considered; (d) the geomembrane should approach the attachment "in-plane" to avoid bridging; (e) the geomembrane should be cushioned or protected from battens, clamps, and bolts; (f) the area of the attachment should be free of dirt and debris; (g) the rigidity of batten strips should be matched to the bolt spacing to provide uniform clamping pressure; (h) gaskets should have proper chemical resistance and not be over-compressed; (i) pre-fabricated corners, edges, and boots should be considered; (j) shape of penetration is ideally round with no corners, having a minimum size of 50 mm dia and a minimum 1 m spacing between penetrations; (k) welding sections of embedment strips (which the Guide refers to as "rondels") together before casting in concrete. The figures in the Guide also indicate that for pipe penetrations the free-field GM should be mechanically attached to a concrete pad, using either embed strips or batten bars, and that the pipe boot skirt should then be welded to the free-field geomembrane outside the limits of the mechanical attachment. Although the Guide does not say why that method is recommended, the current authors agree that this is indeed a very good idea for the primary reason that it will reduce stresses on the geomembrane boot. The figures in the Guide also imply that it is a good idea to use a caulk sealant at the edges of gasketed attachments, and provides examples of double-booted penetrations, both of which we believe are good ideas.

Manufacturers' Literature. Often the last resort utilized by designers and specifiers is a requirement to complete the installation "in accordance with the manufacturer's instructions." This common statement would lead one to believe that the manufacturers would have a wealth of information related to the critical details concerning leak-free attachments. In reality what we find are a library of boilerplate CAD details of pipe boots and batten bar attachments, and generic specifications that are general and non-specific. The one exception is that some installation guides for embedment strips are published by some of the manufacturers, such as the "Polyethylene Embed Channel Specification" by PolyFlex (2008).

Installers. While there is almost no literature that is generally produced by installers, per se, they are in fact the greatest resource of experience and understanding in this field. Most of the information presented in this paper can be attributed to the authors' experience and networks with other installers.

3. ORGANIZATION OF THIS PAPER

There are many variations of boots and attachments to structures. The following sections of this paper will focus on the most common types of boots and attachments encountered by the authors, and will go into detail describing common problems and proposed solutions towards the goal of leak-resistance.

Undoubtedly there are many other variations of geomembrane boots and attachments to structures that have been or will be constructed in the field that are not specifically discussed in this paper. Hopefully the concepts discussed in this paper can be used for those variations as well.

4. LEAK-RESISTANT GEOMEMBRANE BOOTS

A diagram of the most typical geomembrane boot is shown in Figure 1. Photographs of typical boots in the field are shown in Figure 2. A boot consists of the following generic elements:

- Sleeve-to-pipe seal (either welded, or caulked-and-clamped, or gasketed-and-clamped)
- Sleeve
- Sleeve-to-skirt connection

- Skirt (sometimes also called the “flange” of the boot)
- Skirt to free-field geomembrane connection

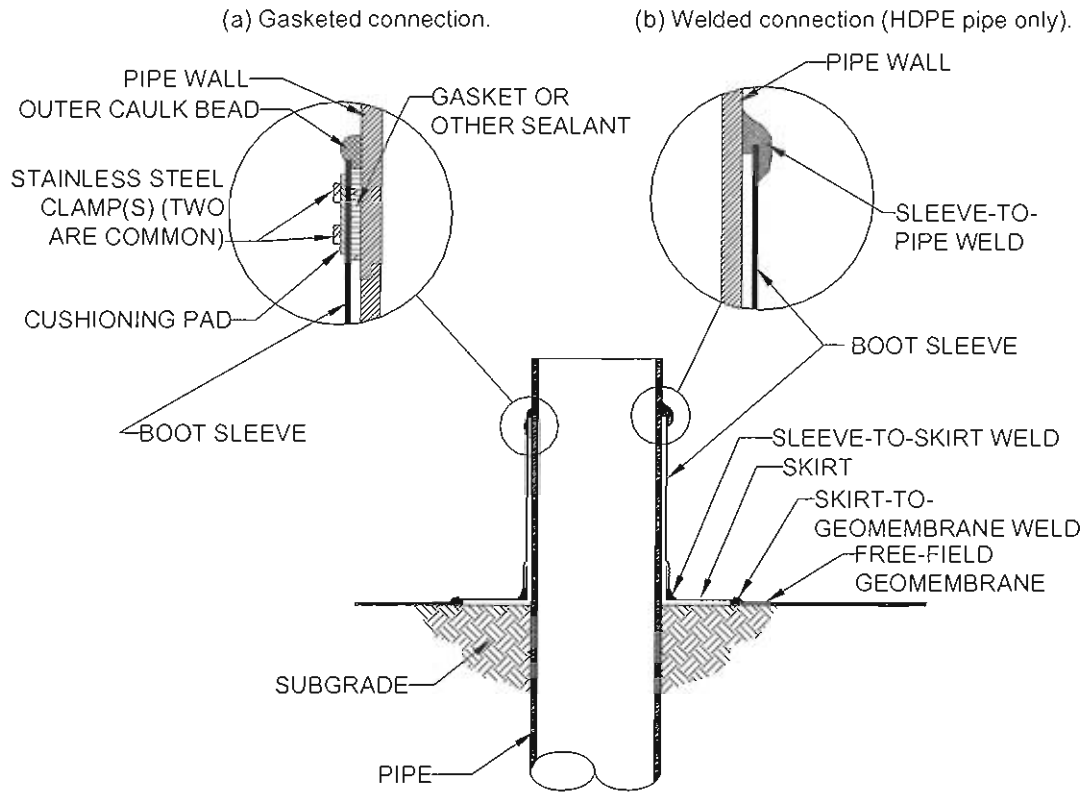
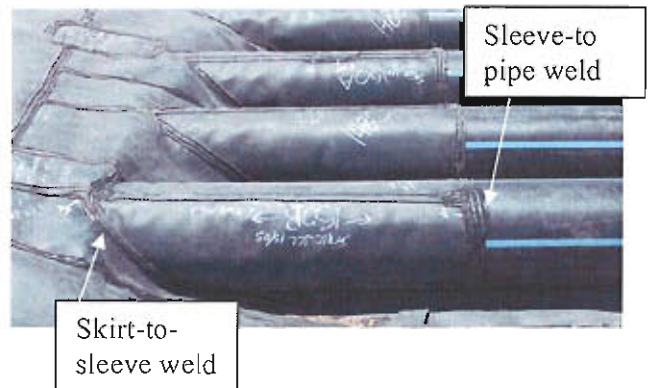

Figure 1. Basic pipe boot elements.



(a) Gasketed and banded boot with polysulfide coating on the end of the boot.



(b) Boot sleeve welded to pipe. This is commonly preferred by many installers for leak resistance.

Figure 2. Typical examples of installed boots.

Prefabricated boots. As suggested by Daniel and Koerner (2005) and by Bonaparte et al. (2002) the use of prefabricated boots is preferable to field-fabricated boots. Prefabricated boots have the sleeve and skirt premanufactured in a single piece, and thus eliminate the sleeve-to-skirt weld, which is often a weak spot. Prefabricated boots made from polyethylene (PE) are often vacuum-formed from base stock material that is substantially thicker than the project-specified geomembrane so that when it is stretched into shape its thinnest spots will have the minimum required thickness. The resulting sleeve will be seamless and will not have a lap joint, which will improve its leak resistance and aid in achieving a uniform clamping pressure. Prefabricated boots from other materials such as EPDM, PVC, or polypropylene can be factory molded or preformed, and sometimes have a stepped-cone or tapered shape where the cone can be cut off at the desired diameter of the pipe.

One of the biggest reasons that the authors have found that prefabricated boots are not used in the industry is because the geometry must be exactly defined ahead of time. The stiffer the geomembrane the more critical this becomes. Often field conditions are slightly different than what is shown on the design drawings. The two most important geometric dimensions that must be accurately defined to order a prefabricated boot are (1) the outside diameter of the pipe, and (2) the angle of the pipe to the subgrade. Having field conditions vary from assumed design conditions is often the "norm" to be expected on construction projects, and even small variations can render a prefabricated boot useless. If the diameter or angle is off, then the integrity of the boot may become compromised due to a poor seal or risking a bridged void at the base of the boot. "It never fits" is a common installer comment regarding prefabricated boots. There is often little incentive for installers to order prefabricated boots because they know the chances of getting the wrong order are high, or waiting to order the boot until the time that the exact field conditions are known will delay a project. Furthermore, there are many instances where the end of the pipe is not accessible and the boot cannot be slipped over the end of the pipe, necessitating a seamed sleeve. And thus the discussion that follows regarding the use field-fabricated boots is most worthwhile.

Clamped and gasketed (or other sealant) connection to pipe. Except in the case of polyethylene geomembranes connected to HDPE pipes, which can have a welded connection, all other boot sleeves will be clamped around the pipe and have either a gasket or other sealant between the pipe wall and the boot sleeve as shown in Figure 1a. The most common problems, and proposed solutions, with these installations are described in the following points, and illustrated in Figures 3 and 4. A checklist of boot issues is provided in Table 1 at the end of this section.

- The gasket material is overlapped and creates a void that may leak at the lap. Solution is to tightly overlap gasket and then cut through both layers of gasket at an angle to obtain a perfect slanted butt-joint.
- The welds are often in difficult geometries and not easily verified for quality. Attempts should be made during design and construction to create good accessibility to all penetrations for good boot construction. All welds should have a copper wire embedded for spark testing (see Figure 4).
- The geomembrane material is overlapped to create the sleeve seam, and creates a void at the edge of the lap that may leak, and also leakage may enter between the two plies of the laps. Solution is to make sure gasket compression fills the void at the edge of the lap, and for very thick geomembrane materials, good craftsmanship would dictate that the edge of the inside of the lap be beveled. Also, provide a seal between the two layers on the lap joint at the outer end of the sleeve to prevent liquid from flowing along that overlap.
- The clamping force from the outer bands or clamps often creates wrinkles in the boot sleeve that may allow leakage. Solution is to have a tight sleeve that will not wrinkle. Start over if it is too loose and there are wrinkles.
- Welds and wrinkles on the boot sleeve cause the clamping force to be uneven which may promote leakage. Solution is to grind and bevel the weld to create a smooth transition so that clamping force is uniform.
- The clamping force on the gaskets is usually not controlled or measured, but is subjectively applied. Clamping with too low or too high of a force may result in a gasket that does not perform properly. There is not a known perfect solution for this issue with gaskets. The best solution is to use a moldable sealant, such as a mastic or a caulk, in lieu of a solid gasket material. Mastics and caulks will fill all of the voids and not be sensitive to compression strain. They generally maintain their elastic-plastic properties for long periods of time, and if chosen properly they will provide some adhesion to the surfaces. Under high-head conditions where there is a concern about plastic-flow of a mastic material, the mastic could be a secondary sealant behind a solid primary gasket.
- Aging and deterioration of the gasket. Solutions are (a) provide a caulk protection bead at the leading edge of the boot to protect the gasket from environmental exposure as much as possible, and (b) periodic inspection and replacement of the caulk bead and the gasket material.
- Most installers believe that permanent-type "band-it" clamps work better than the screw-type clamps because they believe it is difficult to properly light the screw clamps without stripping them, and they

loosen over time. Clamps become loose over time for other reasons, such as thermal expansion and contraction. Solutions are (a) use multiple clamps; (b) routine inspection; (c) on larger-diameter pipes have special two-piece, three-piece, and even four-piece clamps specially fabricated out of 1/8" thick by 1.5" wide stainless steel to the exact diameter of the pipe (allowing for the thickness of the geomembrane and gasket; see Figure 4).

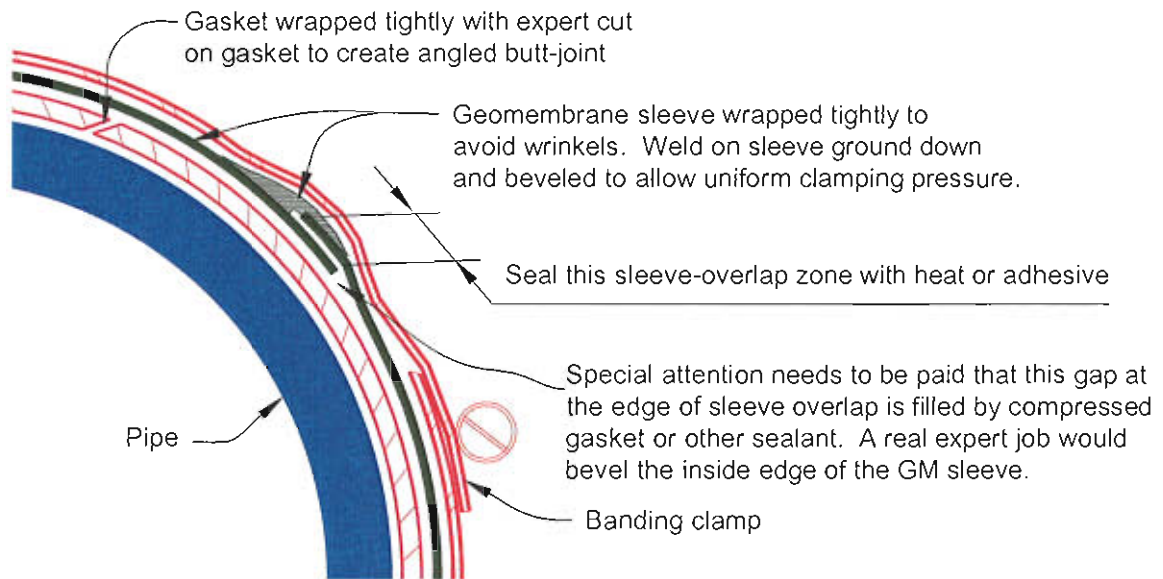

Figure 3. Detail schematic of critical gasketed boot issues.

Note that any gaskets, mastics, or caulks that are used need to be chemically compatible for their intended use. Common mastics are butyl-based (including some that are fuel-resistant) and polyurethane based. Caulks and sealants are most commonly polyurethane, polysulfide, and silicone based, and some may be modified epoxies.

Gaskets are meant to elastically deform and retain resiliency. When they are compressed past their elastic limit, they may lose their resiliency (see Wells, 1993). Gaskets also experience creep over time, and will lose resiliency with time and temperature. The more a gasket is initially compressed, the more accelerated the creep will be. There are differences of opinion regarding gaskets.

The Wells (1993) implies that solid pad gaskets would be used. Many designers and installers use "sponge" gaskets, however, which is lighter weight. If they are used, it is essential that they are specified as "closed cell" materials. The sponge-type gaskets experience a great deal of compression when clamped, and are available in pure or blended varieties of neoprene, polyethylene, nitrile, EPDM, and probably some other materials. Their advantage is that they will have a better chance at filling voids and uneven surfaces than the hard gaskets. Their disadvantage is that they are known to lose their resiliency and retain a set after being clamped down or crushed. Another disadvantage is that sponge gaskets may degrade faster than solid pad gaskets, whether it is due to chemical exposure or UV and oxygen.

Solid gaskets require a smooth, hard, even substrate to create a good seal. It is defeating to have a rough substrate or voids and specify a hard gasket. Unfortunately most of the author's experience is that most concrete surfaces are not in good enough shape to receive a solid pad gasket. Even the overlap on a 60-mil liner may cause too much of a ridge for a solid pad gasket to seal, and the seams in that case would need to be butt-joined or expertly tapered. Solid gaskets are available in natural rubber, neoprene, EPDM, nitrile, Teflon, and likely other materials or combinations. Often the gaskets can be manufactured in different stiffnesses, which is the gasket industry is related to hardness or "durometer". A common specification is for "40-durometer" material.

Moldable sealants and mastics are meant to plastically deform and fill voids. They also have an adhesive quality and tend to stick to surfaces. These materials tend to retain their plasticity, although they may age.



(a) Classic example of poorly constructed boot that violates all good construction principles.



(b) Well-constructed boot (before application of caulk bead).



(c) Thin band clamp that has loosened and come off.



(d) Heavy wide custom clamp around end of a penetration.



(e) Embedding copper wire before weld for spark test.



(f) Conducting hand-held spark test on boot weld.

Figure 4. Examples of poorly- and well-constructed boots.

Caulks, epoxies, and coating are viscous liquids (some even tend to be plastic-deforming solids) that cure and harden over time, but may retain flexibility for a long period of time depending on the material chosen. If chosen properly these materials will adhere to both surfaces after they cure.

In the case of prefabricated boots from very flexible geomembrane materials such as polypropylene, TPO, or EPDM, where the inner diameter of the premolded pipe sleeve is slightly smaller than the outer diameter of the

pipe, and the pipe wall is smooth and clean, it may be possible to slip the boot over the pipe and clamp it with no gasket. This is common in the roofing industry, but even in these cases, a small amount of caulk-sealant is often used between the boot sleeve and the pipe wall.

Welded Boot Connections. Polyethylene geomembranes have a potentially unique advantage if the penetrating pipe is also a polyethylene material in that the geomembrane can be welded directly to the pipe, as illustrated in Figure 1b. Figure 2 shows a classic welded boot installation. Most polyethylene geomembrane installers prefer welding the boot to the pipe for obtaining a leak resistant boot. Geomembrane welds to pipe walls should be field tested for possible delamination as described in Table 1.

Concrete collar at base of boot. The free-field geomembrane is often mechanically connected to a concrete collar that is constructed on the subgrade around the penetrating pipe. The geomembrane's mechanical connection to the concrete can be provided either by an embedment strip or by a batten bar. The reason for the mechanical connection is to relieve any stresses that are attracted from the free-field geomembrane at the pipe boot connection. For example, Figure 5a shows a tear that occurred in the sleeve-to-skirt connection of a pipe boot at the bottom of a reservoir. Figure 5b shows the sinkhole erosion that occurred as a result of the leaking pipe boot, which eventually resulted in a blowout of the downstream dam. Although designers of ponds should always have design elements that can handle leaks of this sort, this type of leak could perhaps have been prevented if a concrete collar had been constructed around the penetrating pipe, with the free-field geomembrane battened to the concrete, and the pipe-boot skirt welded over the top of the batten connection. This recommended collar-design concept is illustrated in Figure 6, similar to what is presented in ASTM D6497.



(a) Failed pipe boot at skirt-to-sleeve weld.



(b) Sinkhole at bottom of reservoir caused by failed pipe boot.

Figure 5. Example of pipe-boot failure and its implication.

Figure 6 shows the free-field geomembrane being attached to embedment strips that would have been cast into the concrete collar. Some contractors have found it simpler to embed polyethylene "stud liner" into the surface of the wet concrete pad, and that would serve the same purpose for mechanical attachment of the free-field geomembrane. Alternatively, if nothing was installed in the concrete ahead of time, the free-field geomembrane could be quickly attached with powder-driven nail anchor battens. A thick geotextile cushion should be used between the skirt and any underlying batten strips.

Polyethylene material is also available in "plate stock" of various thicknesses, which have also been used advantageously to create leak-resistant pipe penetrations, as well as serve a similar function as the concrete collar. The author has dubbed this a "plate boot". In this case the skirt is made from something like 1/2" thick polyethylene plate stock, and is directly welded to the HDPE pipe at the desired angle. Figure 7 shows a field-fabricated plate boot where the plate also has electrically-conductive aluminum tape on the bottom inside and outside edges near where the welds will occur so that the final installation can be spark-tested. This type of boot construction requires attention to pre-heating the thicker pipe and plate-stock materials. Added security could be added to this boot by constructing a standard welded skirt-sleeve assembly that would be welded to the pipe, with the limit of the skirt welding outside the limit of the plate stock. In this manner the skirt would be relatively free of potential stresses, and the thick plate-to-pipe weld, which is susceptible to cracks forming in the weld because of the stiffness of this connection. It is also always good to have redundancy around these penetrations.

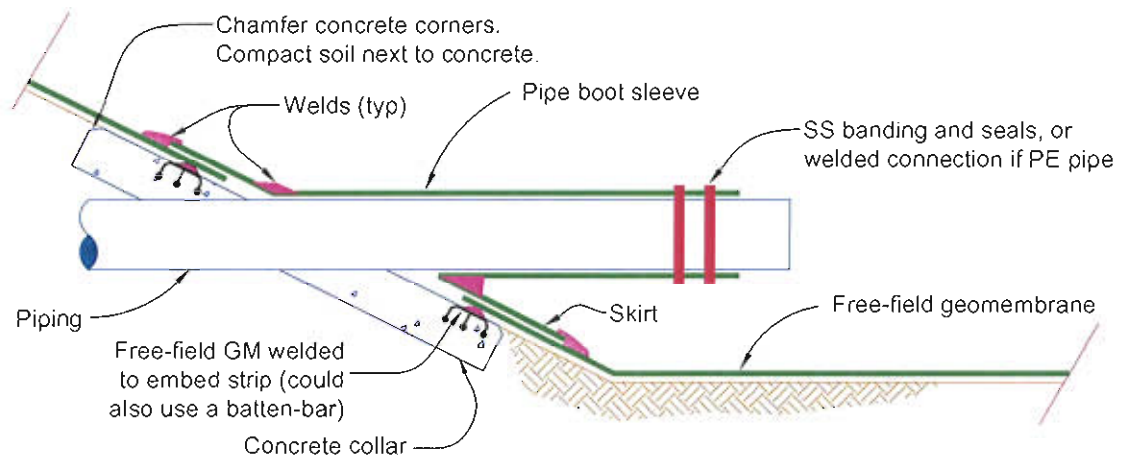

Figure 6. Concrete collar for attachment of free-field geomembrane at base of penetration to keep stress off of skirt-to-sleeve weld (courtesy of GSE Lining Technology).



(a) Fitting plate-skirt.



(b) Applying aluminum tape to bottom of plate for spark test.



(c) Heat-tacking the plate to the free-field geomembrane.



(d) Welding the pipe to the plate. Ideally another welded boot will be installed over this.

Figure 7. Example of "plate-boot" construction.

Figure 8 shows a photograph of another variation on this theme where a small-diameter steel pipe penetrated a concrete wall covered with studliner. In this case a special steel-to-HDPE transition fitting was obtained, a correct-size hole was hole-drilled through the studliner, and installed in the formwork (Figure 8a). After the concrete was placed and the forms were removed, the free-field geomembrane was placed around the pipe and welded to the studliner. A geomembrane skirt was directly welded to the HDPE transition fitting, and the skirt was welded to free-field geomembrane. Note that HDPE-transition fittings are available for different types of metal and PVC pipes in a range of diameters.



(a) Steel-to-HDPE transition fitting in concrete formwork through studliner.

(b) Installed penetration.

Figure 8. Example of welded-boot construction to "studliner" embedded in concrete for a small diameter steel-to-HDPE transition fitting.

Field fabrications of the plate-boot cannot be done if the angle of the slope is too flat or if the pipe penetration is too close to the floor because of the difficulty in getting a weld under the bottom of the pipe. The plate-boot can also be prefabricated in a shop with the plate-skirt shop welded to a pipe section that is delivered to the field. In this case the pipe-and-plate assembly would be set in place in the field (ideally set into a concrete collar, described previously), and the backfill placed behind the plate after it was set. The free-field geomembrane would then be welded to the top of the plate-skirt. Figure 9 shows an example of this with an air-pressure test chamber to verify air-tightness of the penetration. The challenge with these fabrications is getting them to fit the slope in the field, and proper backfilling behind the plate.

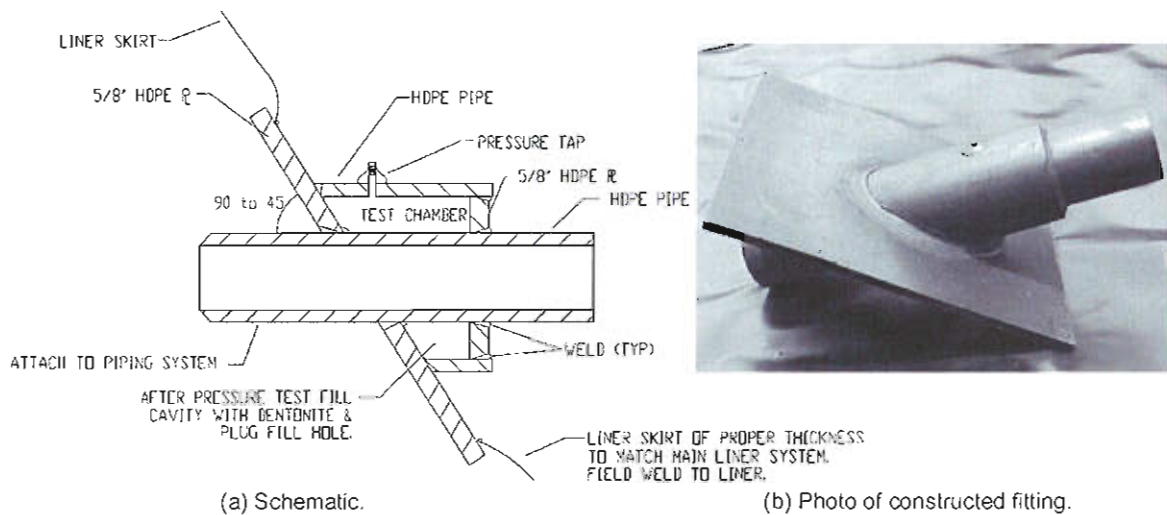

Figure 9. Example of prefabricated "plate-boot" construction (courtesy of GSE Lining Technologies).

Table 1. Checklist of leak-resistant boot issues.

| POTENTIAL PROBLEM WITH BOOT | POTENTIAL SOLUTION |
|---|---|
| General quality | Order prefabricated boots taking care to specify exact OD of pipe and angle to subgrade |
| Stress concentration at base of boot | (a) Construct concrete collar at base of pipe penetration, fasten free-field geomembrane to concrete, and have boot skirt weld over the top of the attachment. (b) Put weights (e.g. continuous sandbags) around all penetrations to take wind stresses off of exposed penetrations. |
| Good weld adhesion when welding to pipe wall or other thick-gage polyethylene | Perform adequate pre-heating where thicker material might cause a heat sink and thus prevents a good weld; test the weld using the field-impact method test to check for potential delamination as follows: place a ½" wide blunt metal tip (e.g. large screwdriver head) against the edge of the extrusion weld and hit it with a rubber mallet. If the weld is not properly bonded it will delaminate. |
| Leaks in boot welds | Spark test all welds associated with the boot by embedding copper wires during construction of the boots. As a supplement, leakage tests can be conducted by pulling a vacuum under the liner and listening with sensitive acoustical equipment for air leakage along the welds. |
| Long-term concern with leaking gasket on polyethylene installations | Specify HDPE pipe for all penetrations, and use HDPE transition fittings for non-HDPE pipe, to allow all penetrations to be welded. |
| Leaking gasket | <ol style="list-style-type: none"> 1. Tightly overlap gasket and then cut through both layers of gasket at an angle to obtain a perfect slanted butt-joint. 2. Tightly wrap and clamp the geomembrane sleeve around gasket to avoid wrinkles. Bevel the inside edge of the overlap. Heat tack and weld the sleeve with the clamps in place. After the weld has cooled or cured, remove the clamps, and weld the remainder of the sleeve seam. 3. Seal the overlap on the geomembrane at the end of the lap joint between the two laps (for PE don't just count on the outer extrusion weld) 4. If there is a thick extrusion weld under the location of where the clamp will go, it needs to be ground down and beveled smooth so that the clamp provides a uniform pressure all the way around. 5. Use double clamp, or use an exact premanufactured multi-piece steel clamp that will clamp over a wide area. 6. Provide double (redundant) boot. |
| Gasket aging and deterioration | Cover the end of the exposed gasket with a caulk. Conduct periodic inspections, caulk maintenance, and replacement as needed. Provide double (redundant) boot. |
| Plastic flow of moldable or mastic sealant under high-head conditions | (a) Provide best-fit solid gasket or cured caulk ahead of moldable sealant, and caulk the end of the penetration to protect the moldable sealant from high heads and high flows. (b) Provide double boot with standard gasket on outer boot and moldable sealant on inner boot. |
| Clamps become loose over time | Options are to (a) use multiple clamps; (b) routine inspection; (c) on larger-diameter pipes have special two-piece, three-piece, and even four-piece clamps specially fabricated out of 1/8" thick by 1.5" wide steel to the exact diameter of the pipe (allowing for the thickness of the geomembrane and gasket). |
| Voids between boot and pipe | Where soil or water pressure will be around the boot it is imperative to have a tight-fitting boot with no voids. |
| Tight geometry | Leave enough space between multiple boots, and all around each boot, to allow for reasonable installation access for welding and clamping, especially in tight corners and underneath the pipe. Leave enough space and slack material to allow for temperature contraction between boots so that cold conditions do not cause bridging at these stiff locations. |
| Dynamic forces | Where penetrating pipes will receive hydrodynamic forces from flowing liquids at elbows near the penetration, design and install provisions, such as thrust blocks, to absorb those forces and keep the stresses off of the welds. |
| Non-circular penetrations | Special problems are created by corners. Band clamps will not work unless they are prebent and there is lots of mastic. Be careful of voids under submerged conditions. Need straight clamps that will exert pressure on each side uniformly. There will need to be extra-care for the wrinkles at the corners. Suggest casting concrete circle around non-circular shapes. |

5. LEAK-RESISTANT GEOMEMBRANE BATTEN ATTACHMENTS

A diagram of the most typical geomembrane batten attachments is shown in Figure 10. Photographs of typical battens in the field are shown in Figure 11. A batten attachment consists of the following generic elements:

- Substrate (usually concrete or steel)
- Gasket (or other sealant)
- Geomembrane
- "Rubber" clamping cushion
- Metal (usually SS) batten bar
- Nuts and bolts (usually SS – although brass nuts are sometimes used)

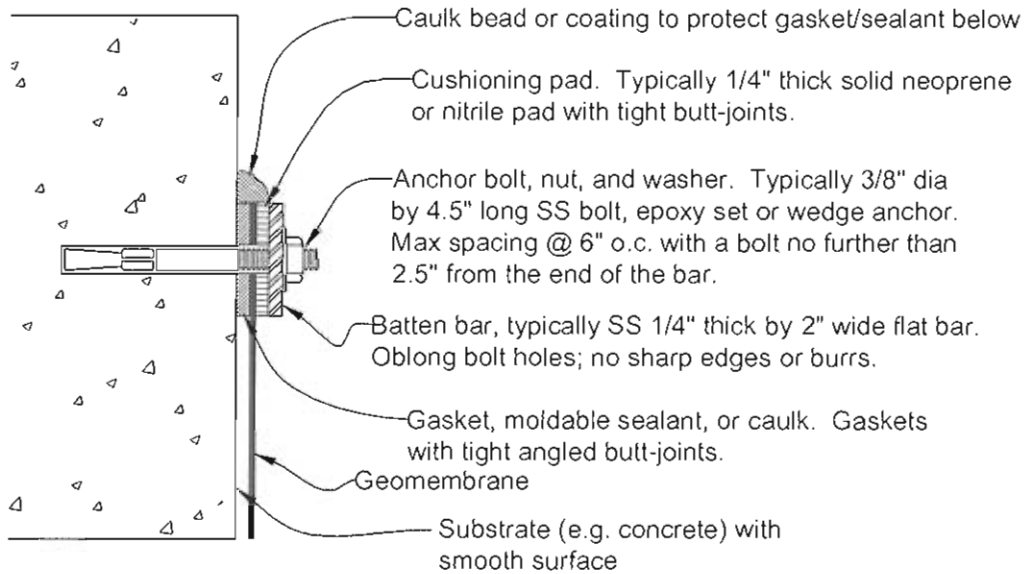

Figure 10. Schematic of typical batten bar elements.



(a) Thick fuel-resistant moldable sealant used to provide leak-resistant seal against rough concrete.



(b) Polysulfide coating over top edge of batten.

Figure 11. Examples of installed batten bars.

When the goal of a batten attachment is not merely as a mechanical connection, but is intended to be leak resistant, then many of the same problems encountered with gasketed pipe boot connections arise with batten attachments. A checklist of batten bar issues is provided in Table 2. Some common problems are illustrated in Figure 12.



(a) Wavy substrate will cause leaks.



(b) Bad concrete joint will defeat batten when submerged.



(c) Hairline crack in concrete will defeat batten when submerged.



(d) Battens at corners need special attention. This one is missing a needed bolt.



(e) Overlapped batten strips are ineffective.



(f) Gasket that was under an overlapped batten showing a section that was crushed past its elastic limit, and a section that was not compressed.

Figure 12. Photos of batten bar problems.

Table 2. Checklist of leak resistant batten bar issues.

| POTENTIAL PROBLEM WITH BATTEN | POTENTIAL SOLUTION |
|--|--|
| Rough substrate | Substrate must be relatively smooth and non-wavy. Rough substrate can be partially compensated with thick moldable sealant. Wavy substrate may require more frequent anchor bolts as well as thick moldable sealant. |
| Stress concentration at base of batten | Put weights (e.g. continuous sandbags) next to all exposed battens to take wind stresses off of battens. |
| Leakage under high head or continuous submergence. | These conditions may warrant closer spacing of anchor bolts, and they may get as close as 3" spacing. The required spacing is related to the batten bar stiffness and the substrate smoothness. Detailed engineering is necessary. |
| Leakage at batten joints | The batten bars must be very closely butted together, but must absolutely not overlap. Anchor bolts should be located within 2" of the end of the batten bar. |
| Leakage past bolt holes | The solutions are: (a) drill gasket holes slightly smaller than bolts; (b) use moldable sealant that deforms around the bolts as it is compressed; (c) drilling bolt holes leaves dust in the hole that can promote leakage, so it is good to vacuum out the dust; (d) put caulk in all bolt holes around the bolts before installing the nuts. |
| Leaking gasket under batten | <ol style="list-style-type: none"> 1. Tightly overlap gasket and then cut through both layers of gasket at an angle to obtain a perfect slanted butt-joint. 2. Tightly fit geomembrane against gasket to avoid wrinkles. Bevel the inside edge of the weld overlaps. 3. Seal the overlap on the geomembrane lap joints between the two laps (for PE don't just count on the outer extrusion weld) 4. If there is a thick extrusion weld under the location of where the batten will go, it needs to be ground down and beveled smooth so that the batten provides a uniform pressure all along its length. Also, a 40-durometer cushioning layer helps distribute the battening force. 5. All of the issues illustrated in Figure 3 for a gasketed boot apply to a batten, where the batten plays the same role as the banding clamp. |
| Long-term gasket crushing | What really matters is gasket compression and not torque. Clamping with too low or too high of a force may result in a gasket that does not perform properly. The solution for this with batten gaskets is to calculate the allowable compression per the method given by Wells (1993), and determine how many turns of the nut will result in an acceptable amount of compression. If this is deemed unreliable, then the best solution is to use a moldable sealant, such as a mastic or a caulk, in lieu of a solid gasket material. Mastics and caulks will fill all of the voids and not be sensitive to compression strain. They generally maintain their elastic-plastic properties for long periods of time, and if chosen properly they will provide some adhesion to the surfaces. Under high-head conditions where there is a concern about plastic-flow of a mastic material, the mastic could be a secondary sealant behind a solid primary gasket. |
| Gasket aging and deterioration | Cover the side of the exposed gasket with a caulk. Conduct periodic inspection, caulk maintenance, and replacement as needed. |
| Plastic flow of moldable or mastic sealant under high-head conditions | Provide best-fit solid gasket and/or cured caulk above a moldable sealant to protect the moldable sealant from high heads and high flows. |
| Anchor bolt nuts become loose over time | Conduct periodic maintenance. Add more bolts if necessary. <i>Do not use rivets or powder-driven nails for leak-resistant battens.</i> You must use nuts and bolts. |
| Maintenance problems when taking off and reinstalling batten bars because bolt threads are nicked and galled | Solutions are: (a) always apply anti-sieze lubricant on threads before installing nuts; (b) consider using brass nuts on stainless steel bolts. The lead author has had great maintenance success with brass nuts without having negative corrosion consequences. |
| Corners | Special problems are created by corners. There will need to be extra-care for the wrinkles at the corners. The batten bars must meet precisely at the corner, and have bolts about 2.5" from the corner without weakening the corner. |

6. LEAK-RESISTANT GEOMEMBRANE CONCRETE EMBEDMENT ATTACHMENTS

A diagram of the most typical geomembrane concrete embedment attachments is shown in Figure 13. Photographs of typical embedment attachments in the field are shown in Figure 14. An embedment attachment consists of the following generic elements:

- Concrete substrate
- Polymeric embedment strips
- Geomembrane welded to embedment

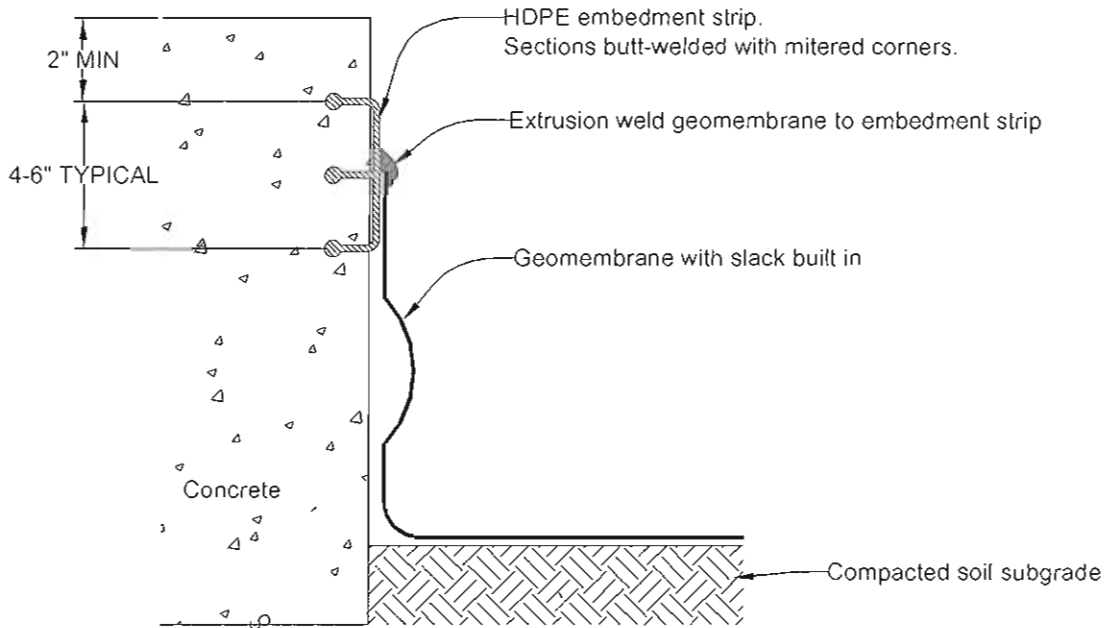

Figure 13. Basic concrete embedment strip elements.



(a) Embedment strip nailed to inside of forms for secondary containment in haz-waste building.

(b) Heat tacking geomembrane to embedment strip after the concrete was placed and forms were removed.

Figure 14. Typical example of embedment strip installation and application.

Embedment strips, called “rondels” in ASTM D6497, are lengths of plastic that are cast into the face of concrete. Embedment strips serve as either simple mechanical attachments where the liner is simply welded to the embedment strip with no other special considerations, or they can serve as a leak-resistant connection that may be submerged.

Some of the first embedment strips were probably PVC “waterstops” that were designed to be cast into the concrete on both sides of a joint, and thus provide a relatively leak-resistant joint. Presumably the PVC waterstop could be embedded in the concrete and be used as an attachment point for a PVC geomembrane, although the lead author would be very suspect of the long-term bond of a geomembrane to a less-plasticized waterstop.

The most popular type of concrete embedment strip that is used for attaching a geomembrane to concrete is made from polyethylene (although the author is aware that similar types of embedment strips are also made from polypropylene and EPDM). The cross sectional shape of the embedment strips varies between manufacturers, but a common cross section is illustrated in Figure 15. A checklist of embedment issues is provided in Table 3.



Figure 15. Cut section through actual concrete embedment strip with welded geomembrane.



Figure 16. Welding geomembrane to embedment strip with preheater on extrusion gun.

Table 3. Checklist of leak-resistant concrete embedment strip issues.

| POTENTIAL PROBLEM WITH EMBEDMENT | POTENTIAL SOLUTION |
|--|---|
| Leakage through concrete or around the embedment | The concrete work must be of a very high quality. It must be properly vibrated. If the concrete is honey-combed, has air voids, or ends up with hairline cracks, then the installation will leak no matter how diligent the welding is performed. Often holes drilled in the embedment strip are advisable to release trapped air. Microfiber reinforcement is recommended. Because of the difference in expansion and contraction between concrete and polyethylene, some amount of leakage can be expected over time. Leakage control is recommended on high-head applications. |
| Leakage by joints of embedment strips | For leak-resistant installations, it is imperative that the embedment strips be butt-fused at their joints, in a similar fashion to HDPE pipe. All corners must be mitered and butt-fused. Leister sells "mirror plates" designed to heat the embed strips for butt-fusing. If the embedment strips are not butt-welded together, then there will always be a possibility of leakage through the gap. If only the face of the butt-joint is welded, there will always be a possibility for leakage to enter the top of the embedment strip where the face-weld ends. |
| Nail holes | The embedment strips should be specified to be nailed to the forms using finishing nails. Screws or large-head nails may cause the embedment strips to be ripped out of the concrete when the forms are pulled off. All nail holes should be welded closed. Pulling a vacuum on a double-liner system to check for leaks with both liners welded to the same embed strip can give a false positive leak due to nail holes. |
| Cold weather welding | Even moderately cold weather can be a problem welding to embedment strips because the concrete is a large heat sink, in addition to the embedment strip being substantially thicker than the geomembrane. Adequate preheating is important. See Figure 16. Check weld bond periodically using field-impact test (see next item) |
| Welding thin gage material to thick material | Because there is no way to perform a destructive test to check the quality of the weld bond, periodically perform a field-impact test to check for potential delamination as follows: place a 1/2" wide blunt metal tip (e.g. large screwdriver head) against the edge of the extrusion weld and hit it with a rubber mallet. If the weld is not properly bonded it will delaminate. |
| Weld leak testing | Always embed a copper wire below the extrusion weld and spark test the weld. As a supplement, leakage tests can be conducted by pulling a vacuum under the liner and listening with sensitive acoustical equipment for air leakage along the welds. |
| Stress concentration at embedment strip due to wind forces | Put weights (e.g. continuous sandbags) next to all exposed embedments to take wind stresses off of welds. |

7. LEAK-RESISTANT PE GEOMEMBRANE TO THICK-WALLED PREFABRICATED HDPE STRUCTURES

Another type of penetration is when a thick-wall HDPE structure, such as a box, sump, or pipe, penetrates into the lined area. The penetration may be through a concrete wall or floor, or through earthen subgrade materials. In this case the geomembrane liner can be welded directly to the structure. There are three considerations that should be taken into account when performing this type of connection:

1. The firmness and evenness of the subgrade immediately adjacent to the structure is important. Specifications should require that the subgrade be flush with the structure so that there is not a sharp discontinuity; and that it be firm and not prone to settlement so that a discontinuity is not formed over time. Even so, it could be a good idea to provide a geotextile cushion strip that bridges the transition from the subgrade to the structure as a preventative measure against potential future settlements.
2. The best designs would have a concrete collar flush around the perimeter of the HDPE structure so that the free-field geomembrane could be bolted (or welded to an embed strip) to the concrete in a purely mechanical fashion. A skirt would then be welded from the free-field geomembrane to the HDPE structure to bridge the gap. The skirt would be largely stress free.
3. Preheat, field-impact test, and spark test procedures as described in Table 3 would be appropriate.

8. RECOMMENDATIONS

In addition to the specific recommendations made in the checklists provided in the main body of this paper, the following general recommendations are suggested as guiding principles for designing and constructing geomembrane penetrations and boots:

- Penetrations and attachments are more susceptible to leakage than the free-field geomembrane liner for many reasons that are discussed in this paper. Owners and designers should always be prepared to manage leakage at these locations. Critical applications should always be designed with redundancy (double liners, double boots, underdrain layers, etc.).
- For exposed and serviceable installations, it is prudent to have a regular inspection and maintenance program for geomembrane penetrations and attachments.
- Penetrations and attachments require a great deal of care and craftsmanship to construct. Designers and CQA personnel should give extra attention to detailing and inspecting these items. Installers should develop in-house standards to assure their own quality of installations.

The discussion provided in this paper should have made it clear that the subject of leak-resistant details is complex and cannot be taken for granted. This situation epitomizes the saying that "the devil is in the details". There are very few technical guidance documents related to these critical aspects of containment construction to aid the specifier and design practitioner, and a lot of faith is usually put on the skill and craftsmanship of the installer. It is hoped that this paper will raise the awareness of the profession to some of the critical issues associated with these details, and that it will lead to higher levels of standardized construction.

ACKNOWLEDGEMENTS

The authors would like to thank Stan Kamienski of NW Linings, Tim Harding of Great Basin Environmental, Bryant Jefferson of Colorado Linings, Andre Harvey of Colorado Linings, Jafer Jaweed from Field Lining Systems, and Dan Murphy, P.E. for their open discussions and providing their opinions as installers.

REFERENCES

- ASTM D6497, Standard Guide for Mechanical Attachment of Geomembrane to Penetrations or Structures, American Society for Testing and Materials, West Conshohocken, Pennsylvania, USA.
- Daniel, D. and Koerner, R.M. (2005). *Waste Containment Facilities: Guidance for CQA and CQC of Liner and Cover Systems*. 2nd Ed., ASCE Press, 354 pgs.
- Bonaparte, R. Daniel, D.E. and Koerner, R.M. (2002). *Assessment and Recommendations for Improving the Performance of Waste Containment Systems*. USEPA Report No. EPA/600/R-02/099, Office of Research and Development, Cincinnati, OH, USA.
- Koerner, R. M. (1994). *Designing with Geosynthetics*. 3rd Ed., Prentice Hall, Englewood Cliffs, NJ, USA.
- PolyFlex (2008). Polyethylene Embed Channel Specification. *Polyflex website*, <http://www.polyflex.com/dropin.html>
- Wells, L. (1993). Guidance for design of watertight geomembrane attachments to concrete surfaces, *Geosynthetics '93*, IFAI, Vancouver, BC, Canada, pp 1119-1129.